



2x2 PM Magnet Optical Switch

Product Description

2x2 optical switch is an all solid-state device without any moving parts. The switching of the optical light is realized by utilizing Faraday Effect. This is achieved using a patent protected non-mechanical configuration with solid-state all-crystal design which eliminates the need for mechanical movement. The microsecond fiber optic switch is designed to meet the most demanding switching requirements of reliability, durability, response, and continuous high frequency switching.

Features

- No moving parts, best durability
- Ultra fast switching speed
- Extremely stable latching mode
- Easy to route -all fibers on same side
- Exceptional reliability and stability

Applications

- Optical switching
- High speed protection
- System monitoring
- Test & measurement
- Fiber-optics sensing system

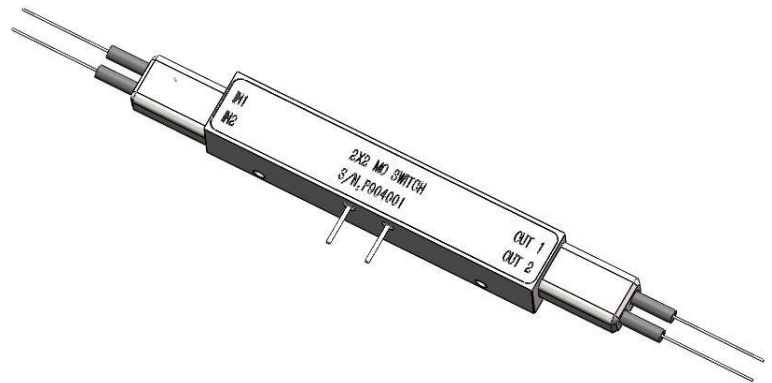

Performance

Item	Unit	Parameters		Notes
		Unidirectional	Bidirectional	
Wavelength Range	nm	1525~1565		Other band optional
Insertion Loss	dB	0.7(Typ.); 1.1(Max)	0.8(Typ.); 1.2(Max)	
PDL	dB	0.10(Typ.);0.20(Max)	0.10(Typ.), 0.30(Max)	
Return Loss	dB	45	30	Typical >50dB
Cross-talk	dB	40	30	Typical >50dB
ER	dB	≥18	≥18	
PMD	ps	0.2		
Repeatability	dB	+/- 0.01		
Durability	cycles	Regular (>100Billions) ; Ultra-fast (>100Billions)		
Switching Speed	μs	Regular (50~200); Ultra-fast (5~20)		Other speed optional
Storage Temperature	°C	-40~85		
Operating Temperature	°C	-5~70		



Maximum Optical Power	mW	500	
Dimension(L×W×H)	mm	63 × 8 × 7	

Note:

1. All the specifications are based on the devices without connectors, and guaranteed over wavelength, polarization and temperature.
2. Specifications are subject to change without notice.

Electrical Specifications

Parameter	Specification		Unit
	Regular	Ultra-fast	
Switching Speed	50~200	5~20	μs
Switching Voltage(VCC)	3(+/-5%)	5.0~6.0	V
Switching Current	< 200	< 500	mA
Pulse Width(typical)	1000	20	μs
Claim Frequency	< 800	< 3000	Hz

Pin control signal corresponding to switching status table

Switching State	Pin1	Pin2	The Optical Output Port
State "0"	1(Voltage = VCC)	0(Voltage = GND)	IN1↔ OUT 1; IN2 ↔ OUT 2
State "1"	0(Voltage = GND)	1(Voltage = VCC)	IN1 ↔ OUT 2; IN2 ↔ OUT 1

Dimensions Drawing (mm)

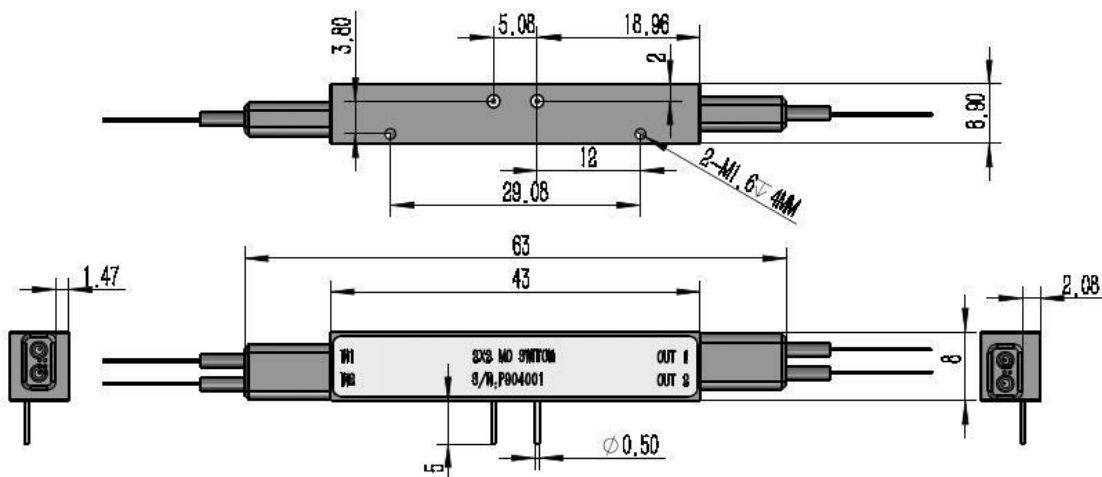

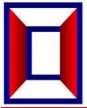

 Ordering Information: Example: HC-PMS2-A-B-C-D-E-F-G

PMS2-	A	B	C	D	E	F	G
	Working Mode	Switching Speed	Operating Wavelength	Fiber Tuber	Fiber Length	Fiber Type	Connector Type
	1. Regular 2. Bidirectional	1. 200~400us 2. 5~20us 3. Others	1.1525~1565 nm 2.1565-1615 nm 3. C & L Band 4. Others	1.250μm fiber 2. 900μm fiber 3. Others	1.0.5 +/- 0.1 m 2. 1.0 +/- 0.1 m 3. Others	1.PM98 2.PM15 3.PM13 4.Others	0.No Connector 1. FC/UPC 2. FC/APC 3. SC/UPC 4. SC/APC 5. LC/PC 6. MU/PC 7. Others